

ORDINANCE

NO. OR09-2017-54

AN ORDINANCE OF THE CITY COUNCIL OF THE CITY OF CLEBURNE, TEXAS, AMENDING TITLE XV: LAND USAGE, CHAPTER 150: BUILDING REGULATIONS, SECTION 150.015 (B) "BUILDING CODES ADOPTED" OF THE CODE OF ORDINANCES ADOPTING THE 2015 EDITION OF THE INTERNATIONAL RESIDENTIAL CODE WITH THE RECOMMENDED AMENDMENTS; PROVIDING THAT THIS ORDINANCE SHALL BE CUMULATIVE OF ALL ORDINANCES; PROVIDING A SEVERABILITY CLAUSE; PROVIDING FOR A SAVINGS CLAUSE; PROVIDING FOR A PENALTY NOT TO EXCEED TWO THOUSAND DOLLARS (\$2,000.00) FOR EACH OFFENSE; PROVIDING FOR PUBLICATION; AND PROVIDING AN EFFECTIVE DATE.

WHEREAS, House Bill 1736 requires all cities within Texas to adopt the 2015 International Energy Conservation Code. Therefore, the North Central Texas Council of Governments (NCTCOG) recommends that all cities adopt the 2015 International Residential Code with their recommended amendments; and

WHEREAS, staff has reviewed the proposed NCTCOG amendments and made any additional changes necessary to meet the needs of the City of Cleburne. Should the City Council approve the proposed Code amendments, the effective date shall be January 1, 2018; and

WHEREAS, staff has developed a public outreach plan to ensure all parties affected by the Code amendments are aware of the updates and any new requirements.

NOW, THEREFORE, BE IT ORDAINED BY THE CITY COUNCIL OF THE CITY OF CLEBURNE, TEXAS:

SECTION ONE. Title XV: Land Usage; Chapter 150: Building Regulations, Section 150.015 (B): Building Codes Adopted, of the Code of Ordinances of the City of Cleburne is hereby repealed in its entirety with amendments and shall hereafter read as follows:

§ 150.015 (B) BUILDING CODE ADOPTED.

(B) The *2015 International Residential Code* as well as recommended amendments are fully incorporated by reference as though copied into this section in its entirety. The material contained in the *International Residential Code* shall not be included in the formal municipal codification of ordinances but shall be maintained as a public record and will be available for public inspection and copying during regular business hours.

SECTION TWO. Cumulative Clause. That this Ordinance shall be cumulative of all other Ordinances and shall not repeal any of the provisions of such Ordinances except for those instances where there are direct conflicts with the provisions of this Ordinance, Ordinances, or parts thereof, in force at the time this Ordinance shall take effect and that are inconsistent with this Ordinance are hereby repealed to the extent that they are inconsistent with this Ordinance. Provided however, that

any complaint, action, claim or lawsuit which has been initiated or has arisen under or pursuant to such other Ordinances on the date of adoption of this Ordinance shall continue to be governed by the provisions of such Ordinance and for that purpose the Ordinance shall remain in full force and effect.

SECTION THREE. Severability Clause. That if any provision or any section of this ordinance shall be held to be void or unconstitutional, such holding shall in no way affect the validity of the remaining provisions or sections of this ordinance, which shall remain in full force and effect.

SECTION FOUR. Savings Clause. That all provisions of the Code of Ordinances of the City of Cleburne, Texas, in conflict with the provisions of this ordinance be, and the same are hereby, repealed, and all other provisions not in conflict with the provisions of this ordinance shall remain in full force and effect.

SECTION FIVE. Penalty Clause. Any person, firm, or corporation who violates, disobeys, omits, neglects, or refuses to comply with or who resists the enforcement of any of the provisions of this ordinance shall be fined not more than Two Thousand Dollars (\$2,000.00) for each offense.

SECTION SIX. Publication Clause. The City Secretary of the City of Cleburne, Texas, is directed to publish the caption, including the penalty of this Ordinance at least once within 10 days after its passage in the official newspaper of the City of Cleburne, Texas, as authorized by Section 3.16 of the Cleburne City Charter.

SECTION SEVEN. Effective Clause. This Ordinance shall become effective January 1, 2018 and upon its publication as required by law.

PASSED AND APPROVED this the 26th day of September, 2017 at a Regular Meeting of the City Council of the City of Cleburne, Texas.



Shelly Doty
Shelly Doty, City Secretary

CITY OF CLEBURNE

BY: 
Scott Cain, Mayor

EXHIBIT "A"

**Amendments to the 2015 International Residential Code
Adopted by Cleburne City Council Ordinance #OR09-2017-54
Section 150.015 (B): Building Codes Adopted**

The following sections, paragraphs, and sentences of the *2015 International Residential Code* are hereby amended as follows: Standard type is text from the IRC. Underlined type is text inserted. ~~Lined through type is deleted text from IRC.~~ A double asterisk at the beginning of a section identifies an amendment carried over from the 2015 edition of the code and a triple asterisk identifies a new or revised amendment with the 2015 code.

In 2009, **the State Legislature enacted SB 1410 prohibiting cities from enacting fire sprinkler mandates in residential dwellings.** However, jurisdictions with ordinances that required sprinklers for residential dwellings prior to and enforced before January 1, 2009, may remain in place. Reference; Section R313 Automatic Fire Sprinkler Systems.

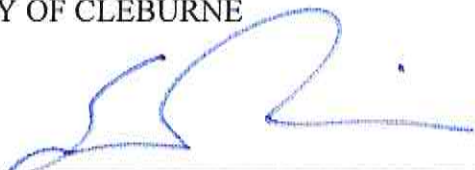
The energy provisions in Chapter 11 of the International Residential Code (IRC) mirror the requirements of the International Energy Conservation Code (IECC). IRC Chapter 11 is deleted in its entirety.

Reference the 2015 IECC for energy code provisions and recommended amendments.

R102.4 Referenced codes and standards. *The codes, when specifically adopted, and standards referenced in this code shall be considered part of the requirements of this code to the prescribed extent of each such reference and as further regulated in Sections R102.4.1 and R102.4.2. Whenever amendments have been adopted to the referenced codes and standards, each reference to said code and standard shall be considered to reference the amendments as well. Any reference made to NFPA 70 or the Electrical Code shall mean the Electrical Code as adopted.*

****Section 103:** City of Cleburne Building Inspection Department.

****103.1 Creation of enforcement agency.** The City of Cleburne Building Inspection Department is hereby created and the official in charge thereof shall be known as the *building official*.

****Section R104.10.1 Flood Hazard areas; (See Chapter 151 of the Code of Ordinances)**

****Section R105.3.1.1& R106.1.4; delete these sections.**

****Section R110 (R110.1 through R110.5); delete the section.**

Delete entire section R112

~~BOARD OF APPEALS~~

~~R112.1 General.~~ ~~In order to hear and decide appeals of orders, decisions or determinations made by the *building official* relative to the application and interpretation of this code, there shall be and is hereby created a board of appeals. The *building official* shall be an ex officio member of said board but shall not have a vote on any matter before the board. The board of appeals shall be appointed by the governing body and shall hold office at its pleasure. The board shall adopt rules~~

of procedure for conducting its business, and shall render decisions and findings in writing to the appellant with a duplicate copy to the *building official*.

R112.2 Limitations on authority. An application for appeal shall be based on a claim that the true intent of this code or the rules legally adopted thereunder have been incorrectly interpreted, the provisions of this code do not fully apply or an equally good or better form of construction is proposed. The board shall not have authority to waive requirements of this code.

R112.3 Qualifications. The board of appeals shall consist of members who are qualified by experience and training to pass judgement on matters pertaining to building construction and are not employees of the *jurisdiction*.

R112.4 Administration. The *building official* shall take immediate action in accordance with the decision of the board.

****Section R202; change definition of "Townhouse" to read as follows:**

TOWNHOUSE. A single-family dwelling unit constructed in a group of three or more attached units separated by property lines in which each unit extends from foundation to roof and with a *yard* or *public way* on at least two sides.

****Table R301.2 (1); fill in as follows:**

GROUND SNOW LOAD	WIND DESIGN				SEISMIC DESIGN CATEGORY ^f	SUBJECT TO DAMAGE FROM			WINTER DESIGN TEMP ^e	ICE BARRIER UNDER-LAYMENT ^h	FLOOD HAZARDS ^g	AIR FREEZING INDEX ⁱ	MEAN ANNUAL TEMP ^j
	SPEED ^d (MPH)	Topographic Effects ^k	Special Wind Region ^l	Windborne Debris Zone ^m		Weathering ^a	Frost Line Depth ^b	Termite ^c					
5 lb/ft	115 (3 sec-gust)/ 76 fastest mile	No	No	No	A	Moderate	6"	Very Heavy	22 ⁰ F	No	Local Code	150	64.9 ⁰ F

****Section R302.1; add exception #6 to read as follows:**

Exceptions: {previous exceptions unchanged}

6. Open non-combustible carport structures may be constructed when also approved within adopted ordinances.

****Section R302.3; add Exception #3 to read as follows:**

Exceptions:

1. {existing text unchanged}

2. {existing text unchanged}

3. Two-family dwelling units that are also divided by a property line through the structure shall be separated as required for townhouses.

*****Section R302.5.1; change to read as follows:**

R302.5.1 Opening protection. Openings from a private garage directly into a room used for sleeping purposes shall not be permitted. Other openings between the garage and residence shall be equipped with solid wood doors not less than 13/8 inches (35 mm) in thickness, solid or honeycomb core steel doors not less than 13/8 inches (35 mm) thick, or 20-minute fire-rated doors equipped with a self-closing device.

****Section R303.3, Exception; amend to read as follows:**

Exception: {existing text unchanged} Exhaust air from the space shall be exhaust out to the outdoors unless the space contains only a water closet, a lavatory, or water closet and a lavatory may be ventilated with an approved mechanical recirculating fan or similar device designed to remove odors from the air.

Section R313 Automatic Fire Sprinkler Systems. Delete subsections in their entirety.

*****Section R315.2.2 Alterations, repairs and additions. Amend to read as follows:**

Exception:

2. Installation, alteration or repairs of electrical powered {remaining text unchanged}

*****Section R322 Flood Resistant Construction. Deleted Section.**

*****Section R326 Swimming Pools, Spas and Hot Tubs. Amended to read as follows:**

R326.1 General. The design and construction of pools and spas shall comply with the International Swimming Pool and Spa Code 2015 IRC Appendix Q. Swimming Pools, Spas and Hot Tubs.

****Section R401.2, amended by adding a new paragraph following the existing paragraph to read as follows.**

Section R401.2. Requirements. {existing text unchanged} ...

Every foundation and/or footing, or any size addition to an existing post-tension foundation, regulated by this code shall be designed and sealed by a Texas-registered engineer.

****Section R602.6.1; amend the following:**

R602.6.1 Drilling and notching of top plate. When piping or ductwork is placed in or partly in an exterior wall or interior load-bearing wall, necessitating cutting, drilling or notching of the top plate by more than 50 percent of its width, a galvanized metal tie not less than 0.054 inch thick (1.37 mm) (16 Ga) and ~~1 1/2 inches (38) mm~~ 5 inches (127 mm) wide shall be fastened across and to the plate at each side of the opening with not less than eight 10d (0.148 inch diameter) having a minimum length of 1 1/2 inches (38 mm) at each side or equivalent. Fasteners will be offset to

prevent splitting of the top plate material. The metal tie must extend a minimum of 6 inches past the opening. See figure R602.6.1. {remainder unchanged}
(Amendment to 2012 IRC carried forward to 2015 IRC.)

****Figure R602.6.1; delete the figure and insert the following figure:**

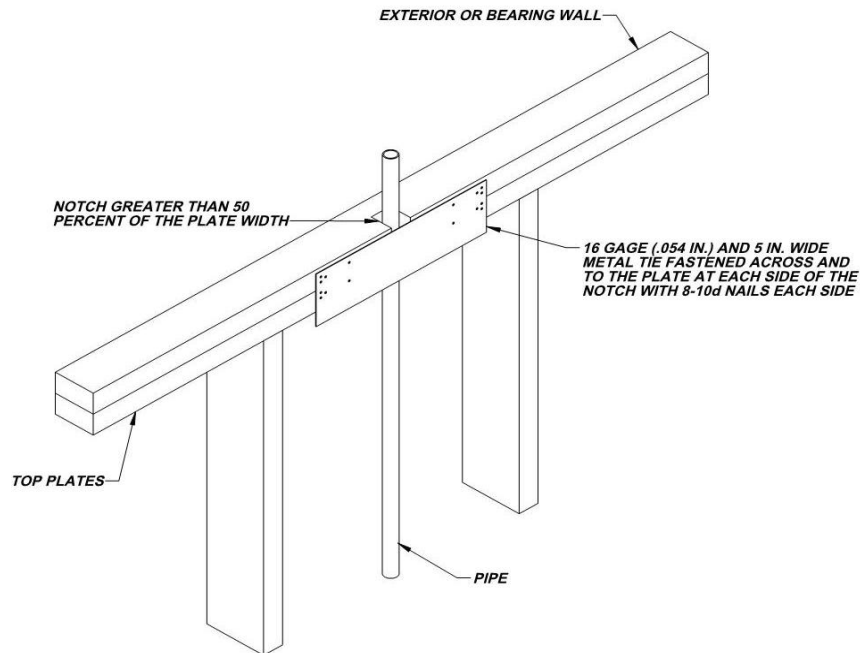

(Amendment to 2012 IRC carried forward to 2015 IRC also provides additional assurance of maintaining the integrity of the framing by spreading the nailing pattern.)

****Section R703.8.4.1; add a second paragraph to read as follows:**

In stud framed exterior walls, all ties shall be anchored to studs as follows:

1. When studs are 16 in (407 mm) o.c., stud ties shall be spaced no further apart than 24 in (737 mm) vertically starting approximately 12 in (381 mm) from the foundation; or
2. When studs are 24 in (610 mm) o.c., stud ties shall be spaced no further apart than 16 in (483 mm) vertically starting approximately 8 in (254 mm) from the foundation.

****Section R902.1; Amend and add exception #3 to read as follows:**

R902.1 Roofing covering materials. Roofs shall be covered with materials as set forth in Sections R904 and R905. Class A, B, or C roofing shall be installed ~~in areas designated by law as requiring their use or when the edge of the roof is less than 3 feet from a lot line.~~ {remainder unchanged}

Exceptions:

1. {text unchanged}

2. *{text unchanged}*
3. *{text unchanged}*
4. *{text unchanged}*
5. Non-classified roof coverings shall be permitted on one-story detached accessory structures used as tool and storage sheds, playhouses and similar uses, provided the floor area does not exceed (area defined by jurisdiction).

***** Chapter 11 [RE] – Energy Efficiency is deleted in its entirety and replaced with the following:**

N1101.1 Scope. This chapter regulates the energy efficiency for the design and construction of buildings regulated by this code.

N1101.2 Compliance. Compliance shall be demonstrated by meeting the requirements of the residential provisions of 2015 International Energy Conservation Code.

****Section M1305.1.3; change to read as follows:**

M1305.1.3 Appliances in attics. Attics containing appliances shall be provided . . . *{bulk of paragraph unchanged}* . . . sides of the appliance where access is required. The clear access opening dimensions shall be a minimum of 20 inches by 30 inches (508 mm by 762 mm), or larger and large enough to allow removal of the largest appliance. A walkway to an appliance shall be rated as a floor as approved by the building official. As a minimum, for access to the attic space, provide one of the following:

1. A permanent stair.
2. A pull down stair with a minimum 300 lb (136 kg) capacity.
3. An access door from an upper floor level.

Exceptions:

1. The passageway and level service space are not required where the appliance can be serviced and removed through the required opening.
2. Where the passageway is unobstructed...*{remaining text unchanged}*

****Section M1411.3; change to read as follows:**

M1411.3 Condensate disposal. Condensate from all cooling coils or evaporators shall be conveyed from the drain pan outlet to ~~an approved place of disposal~~ a sanitary sewer through a trap, by means of a direct or indirect drain. *{remaining text unchanged}*

****Section M1411.3.1, Items 3 and 4; add text to read as follows:**

M1411.3.1 Auxiliary and secondary drain systems. *{bulk of paragraph unchanged}*

1. *{text unchanged}*
2. *{text unchanged}*
3. An auxiliary drain pan... *{bulk of text unchanged}*... with Item 1 of this section. A water level detection device may be installed only with prior approval of the building official.
4. A water level detection device... *{bulk of text unchanged}*... overflow rim of such pan. A water level detection device may be installed only with prior approval of the building official.

****Section M1411.3.1.1; add text to read as follows:**

M1411.3.1.1 Water-level monitoring devices. On down-flow units ...*{bulk of text unchanged}*... installed in the drain line. A water level detection device may be installed only with prior approval of the building official.

****M1503.4 Makeup Air Required Amend and add exception as follows:**

M1503.4 Makeup air required. Exhaust hood systems capable of exhausting in excess of 400 cubic feet per minute (0.19 m³/s) shall be provided with makeup air at a rate approximately equal to the difference between the exhaust air rate and 400 cubic feet per minute. Such makeup air systems shall be equipped with a means of closure and shall be automatically controlled to start and operate simultaneously with the exhaust system.

Exception:

Where all appliances in the house are of sealed combustion, power-vent, unvented, or electric, the exhaust hood system shall be permitted to exhaust up to 600 cubic feet per minute (0.28 m³/s) without providing makeup air. Exhaust hood systems capable of exhausting in excess of 600 cubic feet per minute (0.28 m³/s) shall be provided with a makeup air at a rate approximately equal to the difference between the exhaust air rate and 600 cubic feet per minute.

****Section M2005.2; change to read as follows:**

M2005.2 Prohibited locations. Fuel-fired water heaters shall not be installed in a room used as a storage closet. Water heaters located in a bedroom or bathroom shall be installed in a sealed enclosure so that *combustion air* will not be taken from the living space. Access to such enclosure may be from the bedroom or bathroom when through a solid door, weather-stripped in accordance with the exterior door air leakage requirements of the *International Energy Conservation Code* and equipped with an *approved* self-closing device. Installation of direct-vent water heaters within an enclosure is not required

****Section G2408.3 (305.5); delete.**

****Section G2415.2.1 (404.2.1); add a second paragraph to read as follows:**

Both ends of each section of medium pressure gas piping shall identify its operating gas pressure with an *approved* tag. The tags are to be composed of aluminum or stainless steel and the following wording shall be stamped into the tag:

"WARNING: 1/2 to 5 psi gas pressure - Do Not Remove"

****Section G2415.2.2 (404.2.2); add an exception to read as follows:**

Exception: Corrugated stainless steel tubing (CSST) shall be a minimum of 1/2" (18 EDH).

****Section G2415.12 (404.12); change to read as follows:**

G2415.12 (404.12) Minimum burial depth. Underground *piping systems* shall be installed a minimum depth of ~~12 inches (305 mm)~~ 18 inches (457 mm) below grade, ~~except as provided for in Section G2415.12.1.~~

****Section G2417.1 (406.1); change to read as follows:**

G2417.1 (406.1) General. Prior to acceptance and initial operation, all *piping* installations shall be inspected and *pressure tested* to determine that the materials, design, fabrication, and installation practices comply with the requirements of this *code*. The *permit* holder shall make the applicable tests prescribed in Sections 2417.1.1 through 2417.1.5 to determine compliance with the provisions of this *code*. The *permit* holder shall give reasonable advance notice to the *building official* when the *piping system* is ready for testing. The *equipment*, material, power and labor necessary for the inspections and test shall be furnished by the *permit* holder and the *permit* holder shall be responsible for determining that the work will withstand the test pressure prescribed in the following tests.

****Section G2417.4; change to read as follows:**

G2417.4 (406.4) Test pressure measurement. Test pressure shall be measured with a monometer or with a pressure-measuring device designed and calibrated to read, record, or indicate a pressure loss caused by leakage during the pressure test period. The source of pressure shall be isolated before the pressure tests are made. ~~Mechanical gauges used to measure test pressures shall have a range such that the highest end of the scale is not greater than five times the test pressure.~~

****Section G2417.4.1; change to read as follows:**

G2417.4.1 (406.4.1) Test pressure. The test pressure to be used shall be no less than 3 psig (20 kPa gauge), or at the discretion of the Code Official, the piping and valves may be tested at a pressure of at least six (6) inches (152 mm) of mercury, measured with a manometer or slope gauge, irrespective of design pressure. Where the test pressure exceeds 125 psig (862 kPa gauge), the test pressure shall not exceed a value that produces a hoop stress in the piping greater than 50 percent of the specified minimum yield strength of the pipe. For tests requiring a pressure of 3 psig, diaphragm gauges shall utilize a dial with a minimum diameter of three and one half inches (3 1/2"), a set hand, 1/10 pound incrementation and pressure range not to exceed 6 psi for tests

requiring a pressure of 3 psig. For tests requiring a pressure of 10 psig, diaphragm gauges shall utilize a dial with a minimum diameter of three and one-half inches (3 ½”), a set hand, a minimum of 2/10 pound incrementation and a pressure range not to exceed 20 psi. For welded piping, and for piping carrying gas at pressures in excess of fourteen (14) inches water column pressure (3.48 kPa) (1/2 psi) and less than 200 inches of water column pressure (52.2 kPa) (7.5 psi), the test pressure shall not be less than ten (10) pounds per square inch (69.6 kPa). For piping carrying gas at a pressure that exceeds 200 inches of water column (52.2 kPa) (7.5 psi), the test pressure shall be not less than one and one-half times the proposed maximum working pressure.

Diaphragm gauges used for testing must display a current calibration and be in good working condition. The appropriate test must be applied to the diaphragm gauge used for testing

****Section G2417.4.2; change to read as follows:**

G2417.4.2 (406.4.2) Test duration. The test duration shall be held for a length of time satisfactory to the *Building Official*, but in no case for ~~be not~~ less than ~~40~~-fifteen (15) minutes. For welded piping, and for piping carrying gas at pressures in excess of fourteen (14) inches water column pressure (3.48 kPa), the test duration shall be held for a length of time satisfactory to the *Building Official*, but in no case for less than thirty (30) minutes.

****Section G2420.1 (406.1); add Section G2420.1.4 to read as follows:**

G2420.1.4 Valves in CSST installations. Shutoff valves installed with corrugated stainless steel (CSST) piping systems shall be supported with an approved termination fitting, or equivalent support, suitable for the size of the valves, of adequate strength and quality, and located at intervals so as to prevent or damp out excessive vibration but in no case greater than 12-inches from the center of the valve. Supports shall be installed so as not to interfere with the free expansion and contraction of the system's piping, fittings, and valves between anchors. All valves and supports shall be designed and installed so they will not be disengaged by movement of the supporting piping.

****Section G2420.5.1 (409.5.1); add text to read as follows:**

G2420.5.1 (409.5.1) Located within the same room. The shutoff valve ...{bulk of paragraph unchanged}... in accordance with the appliance manufacturer's instructions. A secondary shutoff valve must be installed within 3 feet (914 mm) of the firebox if appliance shutoff is located in the firebox.

****Section G2421.1 (410.1); add text and Exception to read as follows:**

G2421.1 (410.1) Pressure regulators. A line pressure regulator shall be ... {bulk of paragraph unchanged}... approved for outdoor installation. Access to regulators shall comply with the requirements for access to appliances as specified in Section M1305.

Exception: A passageway or level service space is not required when the regulator is capable of being serviced and removed through the required attic opening.

****Section G2422.1.2.3 (411.1.3.3); delete Exception 1 and Exception 4.**

****Section G2445.2 (621.2); add Exception to read as follows:**

G2445.2 (621.2) Prohibited use. One or more *unvented room heaters* shall not be used as the sole source of comfort heating in a *dwelling unit*.

Exception: Existing approved unvented room heaters may continue to be used in dwelling units, in accordance with the code provisions in effect when installed, when approved by the Building Official unless an unsafe condition is determined to exist as described in International Fuel Gas Code Section 108.7 of the Fuel Gas Code.

****Section G2448.1.1 (624.1.1); change to read as follows:**

G2448.1.1 (624.1.1) Installation requirements. The requirements for *water heaters* relative to access, sizing, *relief valves*, drain pans and scald protection shall be in accordance with this *code*.

***** Section P2801.6.1; change to read as follows:**

Section P2801.6.1 Pan size and drain. The pan shall be not less than 11/2 inches (38 mm) in depth and shall be of sufficient size and shape to receive all dripping or condensate from the tank or water heater. The pan shall be drained by an indirect waste pipe having a diameter of not less than 3/4 inch (19 mm). Piping for safety pan drains shall be of those materials listed in Table 605.4. Multiple pan drains may terminate to a single discharge piping system when approved by the administrative authority and permitted by the manufactures installation instructions and installed with those instructions.

***** Section P2804.6.1; change to read as follows:**

Section P2804.6.1 Requirements for discharge piping. The discharge piping serving a pressure relief valve, temperature relief valve or combination thereof shall:

1. Not be directly connected to the drainage system.
2. Discharge through an air gap ~~located in the same room as the water heater.~~
3. Not be smaller than the diameter of the outlet of the valve served and shall discharge full size to the air gap.
4. Serve a single relief device and shall not connect to piping serving any other relief device or equipment.

Exception: Multiple relief devices may be installed to a single T & P discharge piping system when approved by the administrative authority and permitted by the manufactures installation instructions and installed with those instructions.

5. Discharge ~~to the floor~~, to an indirect waste receptor or to the outdoors.
[remainder unchanged]

****Section P2801.7; add Exception to read as follows:**

Exceptions:

1. Electric Water Heater.

****Section P2902.5.3; change to read as follows:**

P2902.5.3 Lawn irrigation systems. The potable water supply to lawn irrigation systems shall be protected against backflow by an atmospheric-type vacuum breaker, a pressure-type vacuum breaker, a double-check assembly or a reduced pressure principle backflow preventer. A valve shall not be installed downstream from an atmospheric vacuum breaker. Where chemicals are introduced into the system, the potable water supply shall be protected against backflow by a reduced pressure principle backflow preventer.

*****Section P3009.9; change to read as follows:**

P3003.9. Solvent cementing. Joint surfaces shall be clean and free from moisture. A purple primer that conforms to ASTM F 656 shall be applied. Solvent cement not purple in color and conforming to ASTM D 2564, CSA B137.3, CSA B181.2 or CSA B182.1 shall be applied to all joint surfaces. The joint shall be made while the cement is wet and shall be in accordance with ASTM D 2855. Solvent cement joints shall be permitted above or below ground.

Exception: A primer is not required where both of the following conditions apply:

1. ~~The solvent cement used is third-party certified as conforming to ASTM D 2564~~
2. ~~The solvent cement is used only for joining PVC drain, waste, and vent pipe and fittings in not pressure applications in sizes up to and including 4 inches (102mm) in diameter.~~

****Section P3111; delete.**

****Section P3112.2; delete and replace with the following:**

P3112.2 Installation. Traps for island sinks and similar equipment shall be roughed in above the floor and may be vented by extending the vent as high as possible, but not less than the drainboard height and then returning it downward and connecting it to the horizontal sink drain immediately downstream from the vertical fixture drain. The return vent shall be connected to the horizontal drain through a wye-branch fitting and shall, in addition, be provided with a foot vent taken off the vertical fixture vent by means of a wye-branch immediately below the floor and extending to the nearest partition and then through the roof to the open air or may be connected to other vents at a point not less than six (6) inches (152 mm) above the flood level rim of the fixtures served. Drainage fittings shall be used on all parts of the vent below the floor level and a minimum slope of one-quarter (1/4) inch per foot (20.9 mm/m) back to the drain shall be maintained. The return bend used under the drain-board shall be a one (1) piece fitting or an assembly of a forty-five (45) degree (0.79 radius), a ninety (90) degree (1.6 radius) and a forty-five (45) degree (0.79 radius)

elbow in the order named. Pipe sizing shall be as elsewhere required in this Code. The island sink drain, upstream of the return vent, shall serve no other fixtures. An accessible cleanout shall be installed in the vertical portion of the foot vent.

****Appendix Q Reserved. Amended to read as follows:*

Appendix Q. Swimming Pools, Spas and Hot Tubs.

SECTION AQ101 GENERAL

AQ101.1 General.

The provisions of this appendix shall control the design and construction of swimming pools, spas and hot tubs installed in or on the lot of a one- or two-family dwelling.

AQ101.2 Pools in flood hazard areas.

Pools that are located in flood hazard areas established by Table R301.2(1), including above-ground pools, on-ground pools and in-ground pools that involve placement of fill, shall comply with Section AQ101.2.1 or AQ101.2.2.

Exception: Pools located in riverine flood hazard areas which are outside of designated floodways.

AQ101.2.1 Pools located in designated floodways.

Where pools are located in designated floodways, documentation shall be submitted to the building official which demonstrates that the construction of the pool will not increase the design flood elevation at any point within the jurisdiction.

AQ101.2.2 Pools located where floodways have not been designated.

Where pools are located where design flood elevations are specified but floodways have not been designated, the applicant shall provide a floodway analysis that demonstrates that the proposed pool will not increase the design flood elevation more than 1 foot (305 mm) at any point within the jurisdiction.

SECTION AQ102 DEFINITIONS

AQ102.1 General.

For the purposes of these requirements, the terms used shall be defined as follows and as set forth in Chapter 2.

ABOVE-GROUND/ON-GROUND POOL. See "Swimming pool."

BARRIER. A fence, wall, building wall or combination thereof which completely surrounds the swimming pool and obstructs access to the swimming pool.

HOT TUB. See "Swimming pool."

IN-GROUND POOL. See "Swimming pool."

RESIDENTIAL. That which is situated on the premises of a detached one- or two-family dwelling, or a one-family townhouse not more than three stories in height.

SPA, NONPORTABLE. See "Swimming pool."

SPA, PORTABLE. A nonpermanent structure intended for recreational bathing, in which all controls, water-heating and water-circulating equipment are an integral part of the product.

SWIMMING POOL. Any structure intended for swimming or recreational bathing that contains water more than 24 inches (610 mm) deep. This includes in-ground, above-ground and on-ground swimming pools, hot tubs and spas.

SWIMMING POOL, INDOOR. A swimming pool which is totally contained within a structure and surrounded on all four sides by the walls of the enclosing structure.

SWIMMING POOL, OUTDOOR. Any swimming pool which is not an indoor pool.

SECTION AG103 SWIMMING POOLS AQ103.1 In-ground pools. In-ground pools shall be designed and constructed in compliance with ANSI/NSPI-5.

AQ103.2 Above-ground and on-ground pools. Above-ground and on-ground pools shall be designed and constructed in compliance with ANSI/NSPI-4.

AQ103.3 Pools in flood hazard areas. In flood hazard areas established by Table R301.2(1), pools in coastal high-hazard areas shall be designed and constructed in compliance with ASCE 24.

SECTION AQ104 SPAS AND HOT TUBS

AQ104.1 Permanently installed spas and hot tubs.

Permanently installed spas and hot tubs shall be designed and constructed in compliance with ANSI/NSPI-3.

AQ104.2 Portable spas and hot tubs.

Portable spas and hot tubs shall be designed and constructed in compliance with ANSI/NSPI-6.

SECTION AQ105 BARRIER REQUIREMENTS

AQ105.1 Application. The provisions of this appendix shall control the design of barriers for residential swimming pools, spas and hot tubs. These design controls are intended to provide protection against potential drownings and near-drownings by restricting access to swimming pools, spas and hot tubs.

AQ105.2 Outdoor swimming pool. An outdoor swimming pool, including an in-ground, above-ground or on-ground pool, hot tub or spa shall be surrounded by a barrier which shall comply with the following:

1. The top of the barrier shall be at least 48 inches (1219mm) above grade measured on the side of the barrier, which faces away from the swimming pool. The maximum vertical clearance between grade and the bottom of the barrier shall be 2 inches (51mm) measured on the side of the barrier, which faces away from the swimming pool. Where the top of the pool structure is above grade, such as an above-ground pool, the barrier may be at ground level, such as the pool structure, or mounted on top of the pool structure. Where the barrier is mounted on top of the pool structure, the maximum vertical clearance between the top of the pool structure and the bottom of the barrier shall be 4 inches (102mm).

2. Openings in the barrier shall not allow passage of a 4-inch-diameter (102mm) sphere.

3. Solid barriers which do not have openings, such as a masonry or stone wall, shall not contain indentations or protrusions except for normal construction tolerances and tooled masonry joints.

4. Where the barrier is composed of horizontal and vertical members and the distance between the tops of the horizontal members is less than 45 inches (1143mm), the horizontal members shall be located on the swimming pool side of the fence. Spacing between vertical members shall not

exceed 1.75 inches (44mm) in width. Where there are decorative cutouts within vertical members, spacing within the cutouts shall not exceed 1.75 inches (44 mm) in width.

5. Where the barrier is composed of horizontal and vertical members and the distance between the tops of the horizontal members is 45 inches (1143 mm) or more, spacing between vertical members shall not exceed 4 inches (102 mm). Where there are decorative cutouts within vertical members, spacing within the cutouts shall not exceed 1.75 inches (44 mm) in width.

6. Maximum mesh size for chain link fences shall be a 2.25-inch (57 mm) square unless the fence is provided with slats fastened at the top or the bottom which reduce the openings to not more than 1.75 inches (44 mm).

7. Where the barrier is composed of diagonal members, such as a lattice fence, the maximum opening formed by the diagonal members shall not be more than 1.75 inches (44 mm).

8. Access gates shall comply with the requirements of Section AQ105.2, Items 1 through 7, and shall be equipped to accommodate a locking device. Pedestrian access gates shall open outward away from the pool and shall be self-closing and have a self-latching device. Gates other than pedestrian access gates shall have a self-latching device. Where the release mechanism of the self-latching device is located less than 54 inches (1372 mm) from the bottom of the gate, the release mechanism and openings shall comply with the following:

8.1. The release mechanism shall be located on the pool side of the gate at least 3 inches (76 mm) below the top of the gate, and

8.2. The gate and barrier shall have not opening greater than 0.5 inch (13 mm) within 18 inches (457 mm) of the release mechanism.

9. Where a wall of a dwelling serves a part of the barrier one of the following conditions shall be met:

9.1. The pool shall be equipped with a powered safety cover in compliance with ASTM F1346; or

9.2. Doors with direct access to the pool through that wall shall be equipped with an alarm which produces an audible warning when the door and/or its screen, if present, are opened. The alarm shall be listed and labeled in accordance with UL 2017. The deactivation switch (es) shall be located at least 54 inches (1372 mm) above the threshold of the door; or

9.3. Other means of protection, such as self-closing doors with self-latching devices, which are approved by the governing body, shall be acceptable as long as the degree of protection afforded is not less than the protection afforded by Item 9.1 or 9.2 described above.

10. Where an above-ground pool structure is used as a barrier or where the barrier is mounted on top of the pool structure, and the means of access is a ladder or steps, then:

10.1. The ladder or steps shall be capable of being secured, locked or removed to prevent access, or

10.2. The ladder or steps shall be surrounded by a barrier which meets the requirements of Section AQ105.2, Items 1 through 9. When the ladder or steps are secured, locked or removed, any opening created shall not allow the passage of a 4-inch diameter (102 mm) sphere.

AQ105.3 Indoor swimming pool. Walls surrounding an indoor swimming pool shall comply with Section AQ105.2, Item 9.

AQ105.4 Prohibited locations. Barriers shall be located so as to prohibit permanent structures, equipment or similar objects from being used to climb them.

AQ105.5 Barrier exceptions. Spas or hot tubs with a safety cover which complies with ASTM F 1346, as listed in Section AQ107, shall be exempt from the provisions of this appendix

SECTION AQ106 ENTRAPMENT PROTECTION FOR SWIMMING POOL AND SPA SUCTION OUTLETS

AQ106.1 General. Suction outlets shall be designed and installed in accordance with ANSI/APSP-7.

SECTION AQ107 ABBREVIATIONS

AQ107.1 General.

ANSI—American National Standards Institute
11 West 42nd Street
New York, NY 10036

APSP—Association of Pool and Spa Professionals
NSPI—National Spa and Pool Institute
2111 Eisenhower Avenue
Alexandria, VA 22314

ASCE—American Society of Civil Engineers
1801 Alexander Bell Drive
Reston, VA 98411-0700

ASTM—ASTM International
100 Barr Harbor Drive
West Conshohocken, PA 19428

UL—Underwriters Laboratories, Inc.
333 Pfingsten Road
Northbrook, IL 60062-2096

SECTION AQ108 REFERENCED STANDARDS

AQ108.1 General.

ANSI/NSP

ANSI/NSPI- Standard for Permanently Installed
3—99 Residential Spas AQ104.1

ANSI/NSPI- Standard for Above-ground/
4—99 On-ground Residential
Swimming Pools AQ103.2

ANSI/NSPI- Standard for Residential
5—03 In-ground Swimming Pools AQ103.1

ANSI/NSPI- Standard for Residential
6—99 Portable Spas AQ104.2

ANSI/APSP

ANSI/APSP- Standard for Suction Entrapment
7—06 Avoidance in Swimming Pools,
Wading Pools, Spas, Hot Tubs
and Catch Basins AQ106.1

ASCE

ASCE/SEI- Flood-resistant Design and
24—05 Construction AQ103.3

ASTM

ASTM F Performance Specification
1346—91 for Safety Covers and Labeling
(2003) Requirements for All Covers
for Swimming Pools Spas and AQ105.2,
Hot Tubs AQ105.5

UL

UL 2017— Standard for General-purpose
2000 Signaling Devices and
Systems—with revisions
through June 2004 AQ105.2

(Reason: New Pool and Spa code not under review. In lieu of adoption of new pool code, previous edition of 2012 Appendix G is proposed for continued use but renamed 2015 Appendix Q.)

END